

## NPT AU Line Refrigerated Counter 2 Doors (R290)

ITEM # \_\_\_\_\_

MODEL # \_\_\_\_\_

NAME # \_\_\_\_\_

SIS # \_\_\_\_\_

AIA # \_\_\_\_\_



111161 (ZJ2HBAA)

2-door refrigerated  
counter, -2+10°C, AISI 304  
(R290)

### Short Form Specification

**Item No.** \_\_\_\_\_

AISI 304 stainless steel panels, AISI 430 bottom panel, galvanized back panel. Worktop thickness 50mm. N. 2 full doors. Built-in refrigeration unit. Operating temperature: -2+10°C. R290 gas in refrigeration circuit. Supplied with 1 grid for each door compartment

### Main Features

- Adjustable temperature range from -2 °C to +10 °C to suit meat, fish and dairy storage requirements.
- Anti-tilt runners accept GN 1/1 containers.
- Combination of doors and drawers to suit varying needs, with the possibility to change the configuration on site.
- Digital control panel.
- Forced air circulation for rapid cooling and an even temperature distribution.
- Refrigerated compartment designed to accept GN 1/1 containers.
- Self closing stainless steel doors (< 90°).
- Prearranged to fit RS485 port to facilitate connection to a remote computer and integrated HACCP systems.
- 0mm clearance installation space: tower configuration cooling unit guarantee performance with frontal ventilation only; this unique solution allows installation against the wall or side by side with other appliances, even on the cooling unit side to maximize the use of kitchen space.
- Preservation performances and temperature uniformity within the cell guaranteed at 5-HEAVY DUTY (40°C) working conditions according to EN16825:2016 test protocol.
- Combination of doors and drawers to suit any configuration needed, with the possibility to change the configuration on site. Right cooling unit available on request.
- Frontal and easy access to all components in the cooling unit.
- Certified safety CE requirements.
- Small footprint to fit even in limited environments.
- Kit 1/3 drawers available as accessory.
- Tropicalized unit.
- Digital control panel allowing the easy and precise setting and control of the internal temperature.
- Operating temperature can be adjusted from -2 to +10 °C to suit different food storage requirements.
- Complies with main international certification bodies and is CE marked.
- Kit 1/2 drawers available as accessory.
- Completely automatic defrosting and automatic evaporation of frost water by hot gas.
- Forced air cooling system guaranteeing great uniformity of the temperature in the counter and excellent conservation of the food quality.

### Construction

- Access to all components from the front.
- Developed and produced in ISO 9001 and ISO 14001 certified factory.
- Fault code display.
- Interior base with rounded corners, pressed from a single sheet.
- Internal and external doors, front, back and side panels in AISI 304 Stainless steel.
- Mounted on Stainless steel adjustable legs to give 150 mm clearance for ease of cleaning.
- Rounded internal corners for ease of cleaning.
- Pre-arranged for drain-pipe.
- Built-in refrigeration unit.
- Ease of cleaning and high hygiene standards thanks to the

APPROVAL: \_\_\_\_\_

rounded internal corners, the easily removable runners, grids and air conveyors.

- Internal structure with 15 charging positions (3 cm pitch) available to host GN 1/1 grids, ensuring higher net capacity and a greater storage space.
- Extractable cooling unit to facilitate maintenance.
- IP21 protection index.
- Mounted on stainless steel feet to give 150 mm (-5/+50 mm) clearance for ease of cleaning the floor.
- External back panel in galvanized steel.
- Built-in compressor to suit operating conditions.
- Legs in 304 AISI stainless steel (150 mm high, adjustable in height), with plastic interior.
- The door self-closes when opened less than at a 90° angle and is equipped with a door seal to guarantee perfect closure.
- High standards of hygiene and ease of cleaning are guaranteed by the rounded internal corners of the cabinet and easily removable runners and grids.
- Insulation guaranteed by high density expanded cyclopentane 50 mm in thickness.
- Internal and external doors, front and side panels and 50mm thick removable worktop in 304 AISI stainless steel.

- |   |            |                          |
|---|------------|--------------------------|
| • Kit 4 (45mm) spacers for wheels for refrigerator/freezer counters | PNC 881277 | <input type="checkbox"/> |
| • IoT module for refrigerated cabinets and counters                 | PNC 881298 | <input type="checkbox"/> |

### Sustainability

- Removable triple-chamber balloon magnetic gasket to improve insulation and reduce energy consumption and ease of cleaning.
- Hot gas automatic evaporation of defrost water.
- Fitted with 90 mm thickness of cyclopentane insulation for best insulating performance (thermal conductivity: 0,020 W/m\*K) and lowest environmental impact (GWP=3).
- CFC and HCFC free, highly ecological refrigerant type: R290 (ecological gas in foam: cyclopentane). Hydrocarbon refrigerant gas R290 for the lowest environmental impact (GWP=3), to reduce green house and ozone depletion effects.

### Included Accessories

- 2 of Kit 1/1 grey rilsan grid and 2 side runners for refrigerated counters PNC 881109

### Optional Accessories

- |   |            |                          |
|---|------------|--------------------------|
| • 1/1GN grey rilsan grid for refrigerated counters  | PNC 881107 | <input type="checkbox"/> |
| • 2 side runners for 1/1 GN refrigerated counters   | PNC 881108 | <input type="checkbox"/> |
| • Kit 1/1 grey rilsan grid and 2 side runners for refrigerated counters                             | PNC 881109 | <input type="checkbox"/> |
| • 1/1 GN plastic container, H=65 mm   | PNC 881110 | <input type="checkbox"/> |
| • 1/1 GN plastic container, H=100 mm  | PNC 881111 | <input type="checkbox"/> |
| • 2x½ drawer kit for refrigerated counters - h650mm   | PNC 881176 | <input type="checkbox"/> |
| • 3x1/3 drawer kit for refrigerated counters - h650mm (only for refrigerated counters)              | PNC 881177 | <input type="checkbox"/> |
| • 1/3 and 2/3 bottle drawer kit for refrigerated counters - h650mm (only for refrigerated counters) | PNC 881178 | <input type="checkbox"/> |
| • Kit 4 wheels, H=100 mm (2 with brakes) for refrigerated counters                                  | PNC 881191 | <input type="checkbox"/> |
| • Kit 4 wheels, H=150 mm (2 with brakes) for 2&3 compartment refrigerated counters                  | PNC 881193 | <input type="checkbox"/> |
| • Lock for refrigerator/freezer counters with 2 compartments - h650mm                               | PNC 881245 | <input type="checkbox"/> |

**Front**

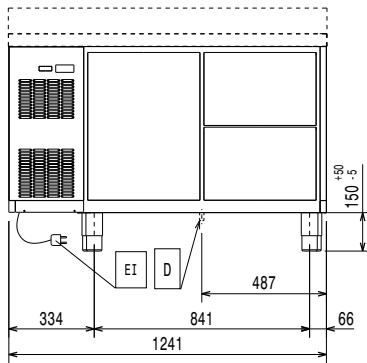

**Side**

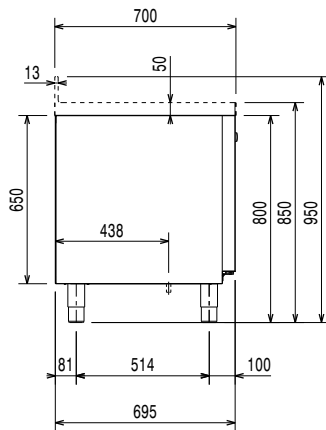

EI = Electrical inlet (power)

**Top**

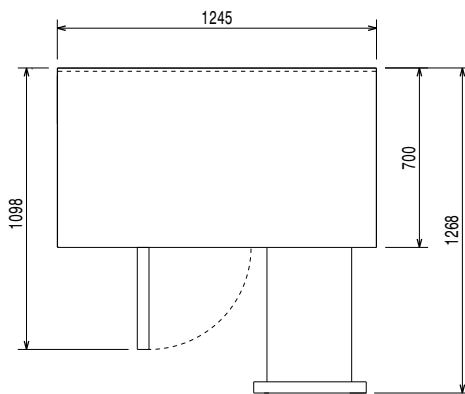

**Electric**

Supply voltage: 220-240 V/1 ph/50 Hz  
Electrical power, max: 0.22 kW

**Key Information:**

Net Volume: 163.6 lt  
External dimensions, Width: 1245 mm  
External dimensions, Depth with Doors Open: 1310 mm  
External dimensions, Height: 850 mm  
Net weight: 94 kg  
Worktop type: Stainless Steel  
Gross capacity: 290 lt  
Built-in Compressor and Refrigeration Unit

**Refrigeration Data**

Control type: Digital  
Min/Max internal humidity: 40/85  
Operating temperature min.: -2 °C  
Operating temperature max.: 10 °C  
Compressor power: 1/4 hp  
Operating mode: Ventilated

**Sustainability**

Noise level: 48 dBA  
Refrigerant type: R290  
GWP Index: 3  
Refrigeration power: 320 W  
Refrigerant weight (unit 1): 45 g  
Energy Class (EU Reg. 2015/1094): B  
Yearly and daily energy consumption (EU Reg. 2015/1094): 560kWh/year - 1.53kWh/24h  
Climate class (EU Reg. 2015/1094): Heavy Duty (5)  
Energy Efficiency Index-EEI (EU Reg. 2015/1094): 25,36

**EU energy labelling from 1st July 2016**

The European energy labelling scheme for professional refrigerators and freezers is based on requirements setting Minimum Energy Performance standards for commercial refrigeration cabinets sold within the EU. These requirements are designed to drive energy efficiency and environmentally friendly approach for professionals. The European energy labelling scheme will apply to all manufacturers and importers who sell and market products within the EU and it is mandatory across Europe. Important: all products which consume energy above the minimum level will not be able to be sold within the EU from 1 July 2016.

SI 2020 No. 1528.

Important: all products which consume energy above the minimum level will not be able to be sold within the EU from 1 July 2016.

